

Bu Çizim MESA OTO ELEKTRİK LTD.ŞTİ'nin malıdır. Şirket Yetkililerinin izni olmaksızın kopya edilemez, üzerinde değişiklik yapılamaz. This Drawing MESA AUTO ELECTRIC LTD 's are property. Can not be copied without the consent of the company authorized, any changes can be made.

PARÇA KODU PART CODE	PARÇA ADI PART NAME	s ÖLÇÜSÜ (KALINLIK) s MEASURE (THICKNESS)	Malzeme Material	Kaplama / Coating		
				SN	AG	Nİ
TEK 2862 RP	EK BİRLEŞTİRME (TKT 99) =RP=	-----	(CuZn30) Pirinç / Brass	-	-	-
TEK 2862 RPK	EK BİRLEŞTİRME (TKT 99) =RPK=	-----	(CuZn30) Pirinç / Brass	+	-	-

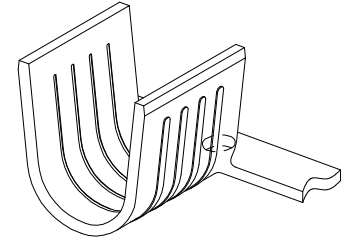
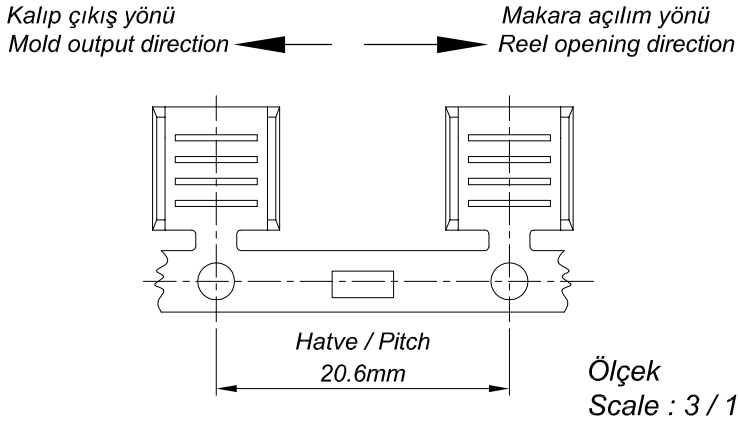
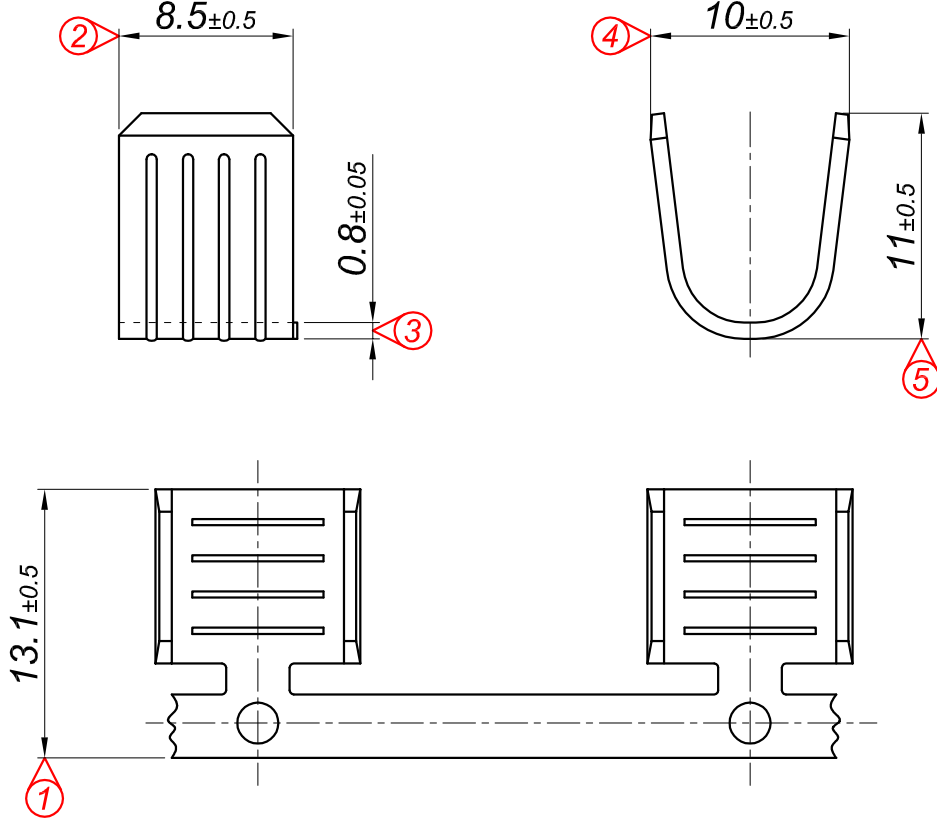

Kablo Kesiti
Wire Section : 8 - 10 mm²

Resmin Üzerinden Ölçü Almayınız
Don't use the drawing for measuring purpose

Tarih / Date	28.11.2013	İmza /Signature	Ölçek / Scale			
Çizen / Desing	M.Yağcı					
Onay / Approval	S.Gölcük		3 / 1	No	Değişiklik / Revision	Tarih/Date
	Parça Adı: Part Name	EK BİRLEŞTİRME (TKT 99)	Parça Kodu: Part Code		TEK 2862	

